

Swivel Selflock Hook

- Forged super alloy steel-Quenched and tempered
- Individually proof test at 2.5 times working load limit.
- Fatiuge tested for 20000 cycles.
- Breakage test
- 100% magnaflux crack detection.
- Suitable for EN818-2 G80 chain.
- Safety factor 4:1
- Surface finish: Powder plastified.

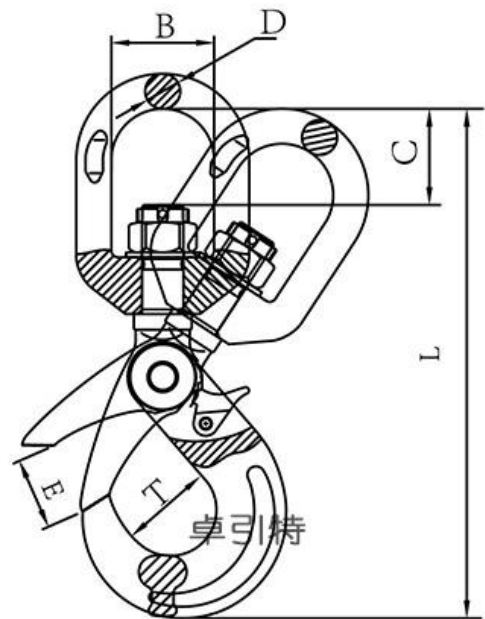

ITEM NO.	Size (mm)						WLL	Breaking Strength	Weight
	B±2	C±2	D±2	L±2	T±2	E±2	T	T	Kg
8-083-06	32.5	22	11.25	170	34	29	1.12	4.48	0.71
8-083-7/8	35.5	26	12.5	210	46	34	2	8	1.1
8-083-10	42	34	15	247	56	44	3.15	12.6	2
8-083-13	50	38.5	16	302	69	52	5.3	21.2	4
8-083-16	61	55	21.5	383	86	60	8	32	7.3
8-083-20	72	61	26	418	100	83	12.5	50	11.6
8-083-22	95	95	33	527	108	88	15	60	16
8-083-26	122	115	42	610	110	95.5	21.2	84.8	21.5
8-083-32	140	126	52	777	166	150	31.5	126	79

G100 Swivel Selflock Hook

- Forged super alloy steel-Quenched and tempered.
- 25% stronger than G80.

- Individually proof test at 2.5 times working load limit.
- Fatigue tested for 20000 cycles.
- Breakage test
- 100% magnaflux crack detection.
- Suitable for G100 chain.
- Safety factor 4:1
- Surface finish: Powder plastified.

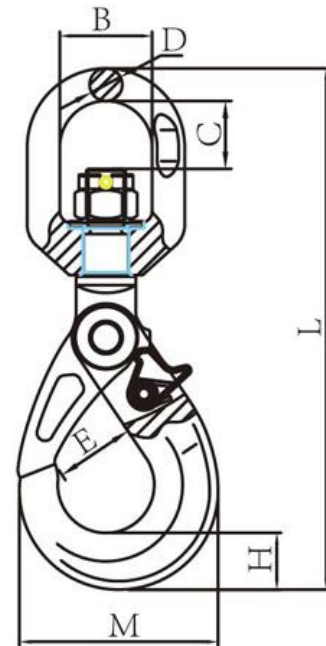

ITEM NO.	WLL	Breaking Strength	Size (mm)							Weight
	T		T	B±1	C±1	D±0.5	E±1	H±1	M±2	
10-1007-06	1.4	5.6	32.5	23	11.5	28	20	70	184	0.6
10-1007-08	2.5	10	36	28	13	35.5	26	90	229	1.1
10-1007-10	4	16	42	35	15.5	45	30	108	269	2
10-1007-13	6.7	26.8	50	40	17	53.5	40.5	138.5	330	4
10-1007-16	10	40	61	56	21.5	62	50.5	170.5	413	6.8
10-1007-20	16	64	72	62	26	76.5	62	192.5	463	12.5
10-1007-22	19	76	97	94	33	80	66	205	572	17.1